

INCREASED COUNTERWEIGHT INSTALL

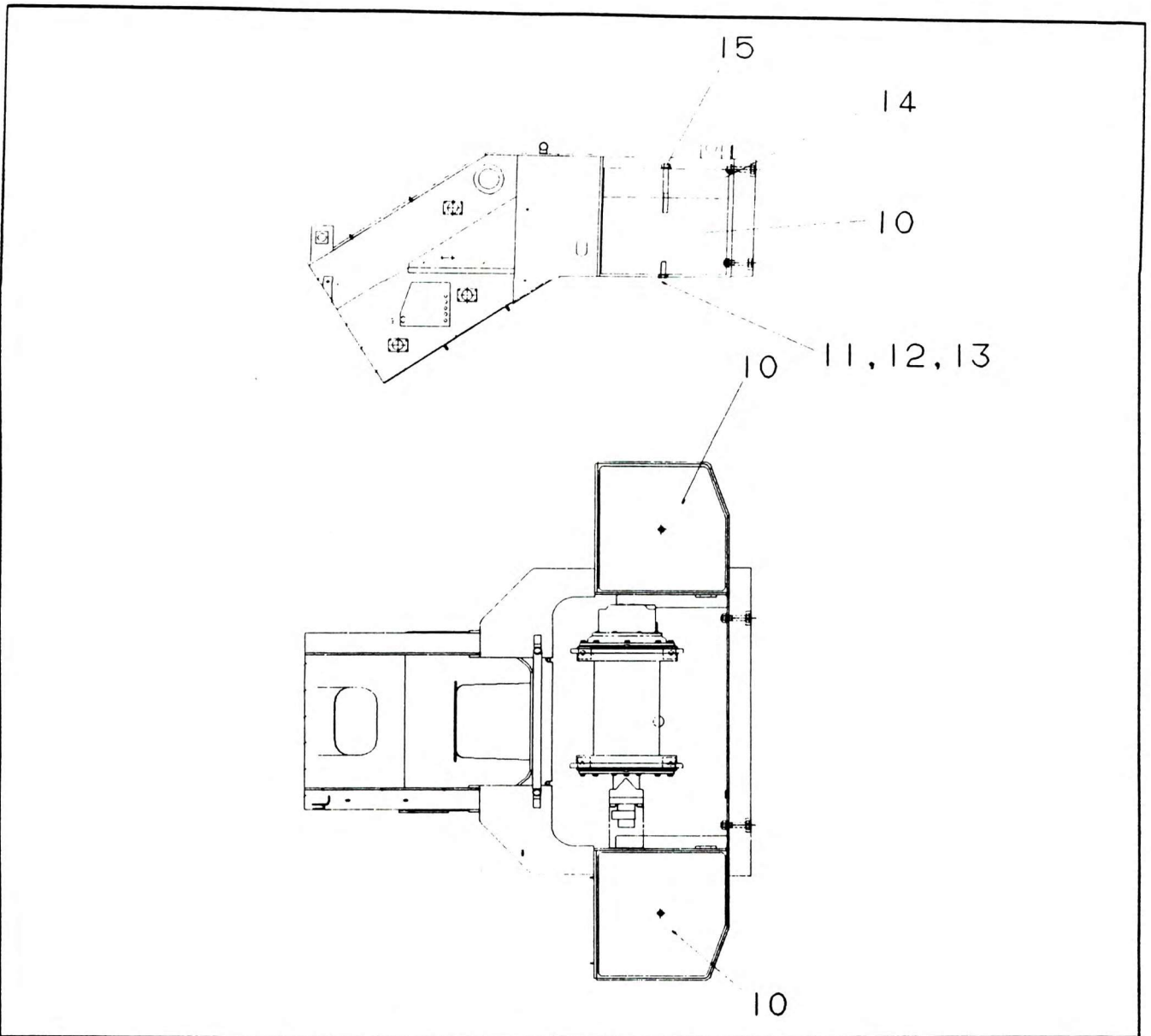

NO.	PART NO.	QTY.	DESCRIPTION	NO.	PART NO.	QTY.	DESCRIPTION
10	6-962-990264	2	Counterweight 1380 kg				
11	7-126-292550	2	Bolt M24 x 90mm Lg				
12	7-951-290014	4	Washer M24				
13	7-951-290210	4	Spring Washer 24 I/D				
14	6-962-990275	2	Counterweight 200kg				
15	7-126-292950	2	Bolt M24 x 130 Lg				